

10MHz - 200MHz series

Frequency Range	周波数範囲	10MHz ~ 200MHz
Crystal Cut	カット	AT
Mode of Oscillation	振動モード	Fundamental, 3rd, 5th
Frequency Tolerance (at25°C)	周波数偏差	±2.5 ~ ±50ppm
Load Capacitance	負荷容量	Please Specify
Shunt Capacitance (CO)	並列容量	7pF max
Drive Level	励振レベル	10 ~ 2000 μW
Aging	エージング	±1 ~ ±5ppm / year
Storage Temperature Range	動作温度範囲	-40 ~ +85°C
Case Type	ケース	UM-5, UM-5S

Frequency and Equivalent Series Resistance (E.S.R)

Frequency (MHz)	Mode	E.S.R (Ω)
8 ~ 10	Fundamental	50
10 ~ 20	Fundamental	30
20 ~ 60	Fundamental	25
24 ~ 30	3rd OT	80
30 ~ 60	3rd OT	60
60 ~ 180	3rd OT	40
80 ~ 120	5th OT	100
120 ~ 200	5th OT	80

Frequency Stability

Operating Temp. Rang	Stability	
	0 ~ 50°C	±2.5ppm MIN
-5 ~ 55°C	±5.0ppm MIN	
-10 ~ 60°C	±5.0ppm MIN	
-15 ~ 65°C	±7.0ppm MIN	
-20 ~ 70°C	±7.5ppm MIN	
-25 ~ 75°C	±10.0ppm MIN	
-30 ~ 80°C	±12.0ppm MIN	
-40 ~ 85°C	±15.0ppm MIN	

Dimensions(Unit:mm)

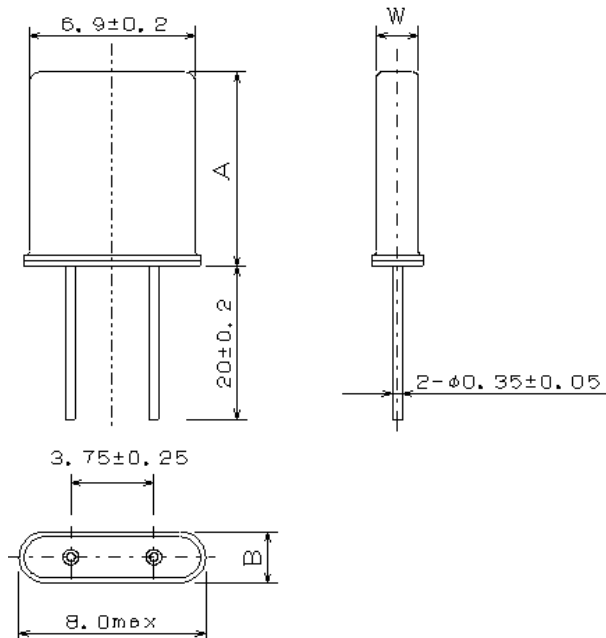

Case	A	B	W
UM-5	6.0max	3.0 ± 0.2	2.2 ± 0.2
UM-5S	6.0max	2.5 ± 0.2	1.8 ± 0.2

C4-5のMJタイプも対応可能です。
Even the MJ type of C4-5 is possible correspond.